

I Applications

The DIN-TEX is a sanitary high-capacity centrifugal pump (up to 1000m³/h). It is designed to work with a basic or semi-finished product. Its applications also include processes of the food-processing industry like wine-making, or textile and chemical industries which are not characterised by strict hygienic requirements.

Owing to the high flow, the pump is also suitable for the transfer of cleaning solutions.

I Operating principle

Housed inside the casing, the impeller rotates in conjunction with the pump shaft. With this arrangement, the impeller blades convey energy to the fluid in the form of kinetic energy and pressure energy.

This pump is not reversible by simple reversal of the direction of rotation. The direction of rotation is clockwise when the pump is viewed from the rear side of the motor.

I Design and features

8 mm cold-formed plate casing with volute.

Flanges: PN16 according to DIN2633.

Double-curvature impeller with blades on the rear side.

Axial adjustment of the impeller.

Single mechanical seal according to EN12756 L1K.

Fully-drainable pump.

IEC B3 (B35 close-coupled models) motors, IP55, F-class insulation.

Drain port: G ½" (BSP).

I Materials

Parts in contact with pumped media:

AISI 316L

Lantern and bearing support:

GG-22

Gaskets (standard):

EPDM according to FDA

Mechanical seal (standard):

SiC/C/EPDM

Internal surface finish of the casing and impeller:

Blasted

External surface finish:

Blasted

I Options

Close-coupled construction for model 250.

SiC/SiC mechanical seal for abrasive media.

Back-to-back pressurised or flushed double mechanical seal.

Gaskets: FPM(Viton®) and PTFE.

Motor shroud.

Motors with other protections.

Stainless steel or iron baseplate.

Flanges PN16 DIN 2633



Drain port G ½"

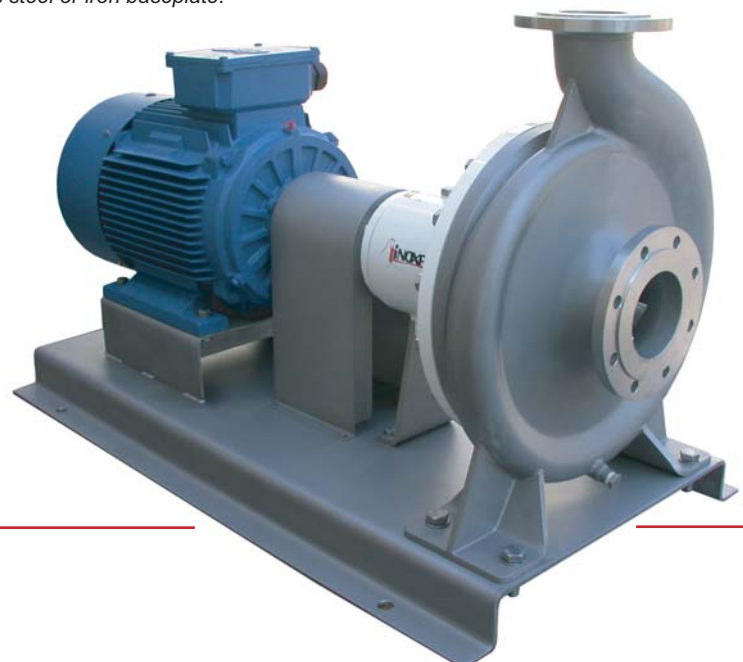

I Technical specifications

Max. flow	1000 m ³ /h	4440 US GPM
Max. differential pressure	9 bar	131 PSI
Max. working pressure	20 bar	290 PSI
Max. working temperature	120 °C	248°F
Max. speed	1750 rpm	

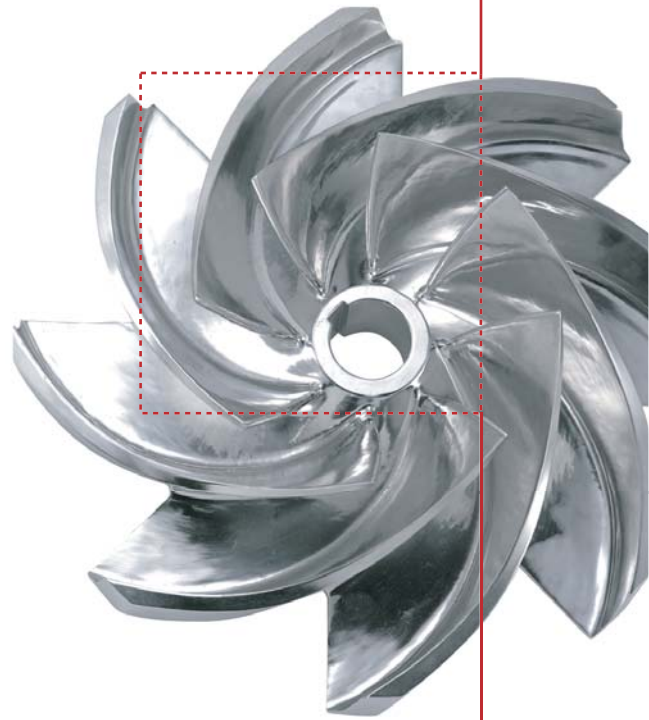
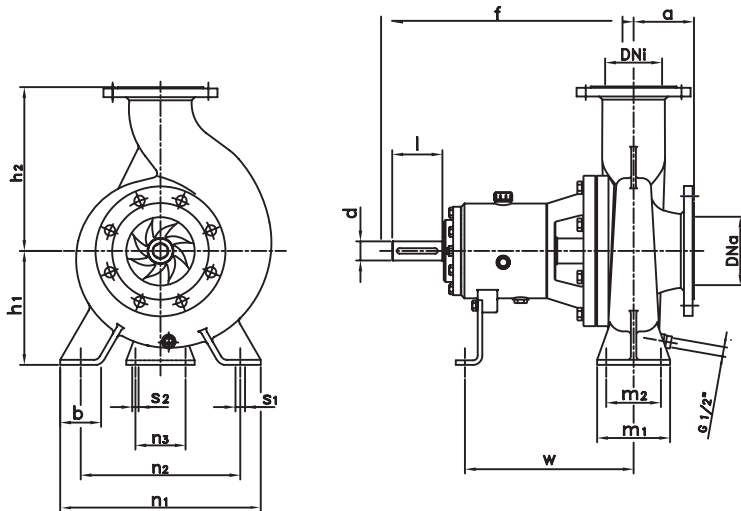

PUMP TYPE	DNa	DNi	d	l	a	f	h1	h2	b	m1	m2	n1	n2	n3	s1	s2	w
125-100-250	125	100	42	110	126	522	250	323	90	160	120	440	350	110	18	14	363
125-100-315					510	280	358	490				400	350				
125-100-400					135	330	408	100	200			150	550		450	23	370
150-125-250	150	125	42	110	133	530	250	360	90	160	120	440	350	110	18	14	370
150-125-315					142	280	377	490				400	400				
150-125-400					145	518	330	426	100			200	150		550	450	23
200-150-250	200	150	42	110	150	537	250	380	90	200	150	440	350	110	14	18	378
200-150-315			48		160	670	280	405				490	400				140
200-150-400			667		330	456	100	550	450			498					

PUMP TYPE	MOTOR	DNa	DNi	a	f	h1	h2	b	c	c1	c2	l	m1	m2	n1	n2	n3	n4	s1	s2	w
125-100-250	160	125	100	126	855	250	323	90	68	360	260	460	160	120	440	350	415	470	18	18	342
	180				935																475
150-125-250	160	150	125	133	870	340	360	90	88	400	305	460	200	150	600	545	545	600	23	23	349
	180				950																475
200-150-250	180	200	150	150	1015	340	380	68	88	400	305	585	210	150	600	545	545	600	23	23	381
	200				1015																585

